

IBC TANKS

THE IBC TOTES AUTHORITY

Megatainer IBC Tote

550 MEGATAINER PREMIUM STANDARD

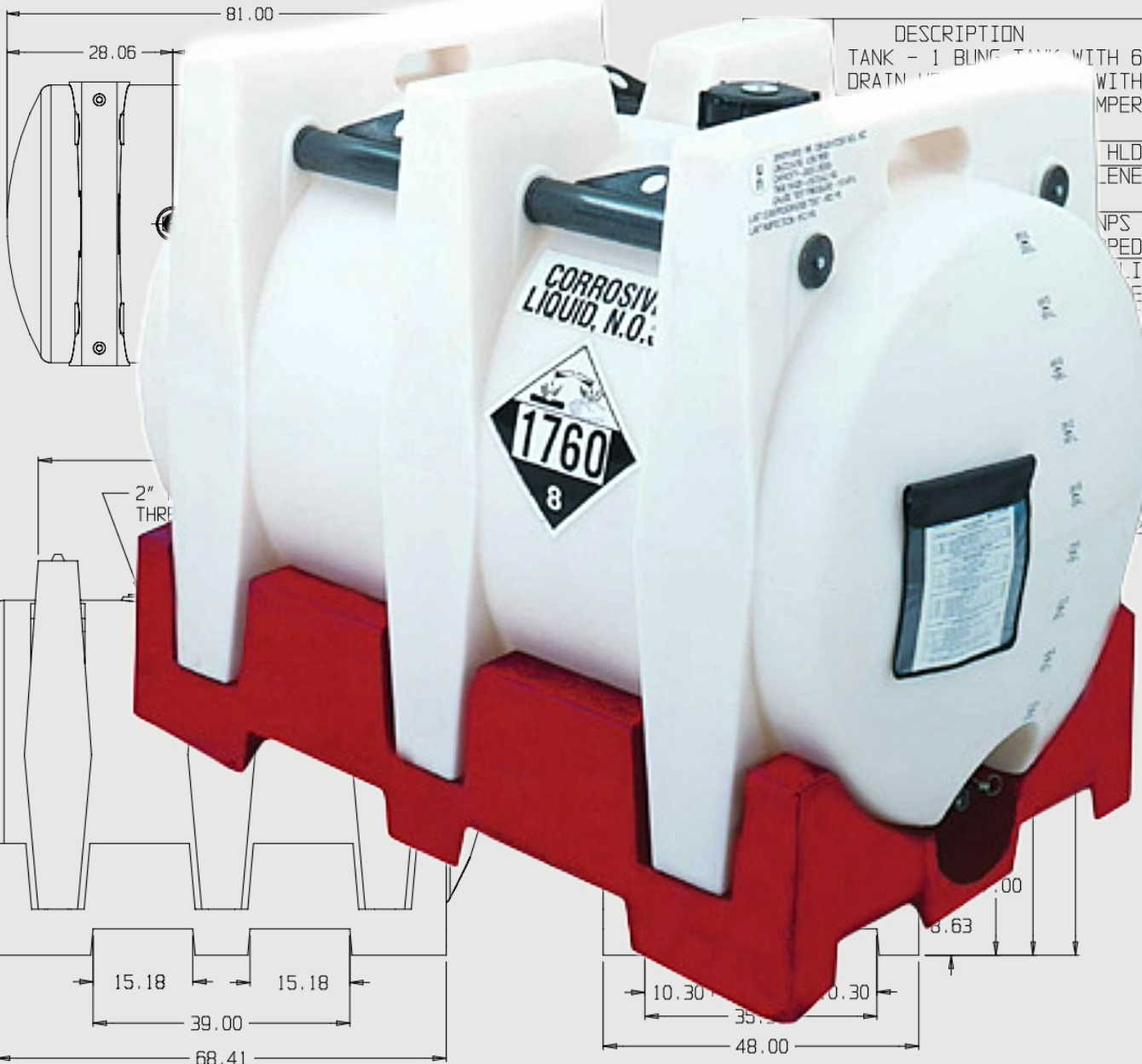

DESCRIPTION
TANK - 1 BUNG TANK WITH 6.5" CAP AND BOTTOM DRAIN

WITH CAP LANYARD
EMPER EVIDENCE INSERTS

HLDPE RED,
LENE BUNG PLUGS WITH

NPS CENTER OPENING AND
EPPED WITH LID TIE

RELIEF VENT WITH EPDM
AVERAGE GRAVITY FLOW
(N/LITE)

FILLED POLYPROPOL
TEFLON SEATS AND E
IDES DUST CAP AND

79,580
2 PLACES.

NOTE ! OPTIONAL
AVAILABLE ON CON

THIS TANK HAS BEEN
REQUIREMENTS PER
FOR RIGID PLASTIC
FOR LIQUIDS INTER
MATERIALS. (IDENT
II AND GROUP III
SEE 49 C.F.R. PART
PACKAGING AUTHORITY

TANK MARKING:



(855) 445-7665



sales@ibctanks.com

About

Megatainer IBC tanks are the largest all-polyethylene intermediate bulk container available for industry and business professionals. With a 550 gallon volume capacity, the Megatainer is equivalent to ten 55 gallon drums or two limited use 275 gallon IBCs.

Store more cargo in a single container with the Megatainer. Rotational mold manufactured to a 1/2" thickness from high-density polyethylene, the Megatainer provides a lasting, reusable, heavy-duty IBC that outperforms other transit container options.

The Megatainer is engineered with a cylindrical, horizontal tank and structural support ridges, that together increases overall strength. Paired with the handling, filling, and dispensing feature benefits of an IBC container, the Megatainer is a long lasting, high volume, heavy-duty asset that provides superior reusability, durability, versatility, and integration with an excellent cost-to-service life ratio.

Megatainers are premium options for industries, suppliers, production and distribution companies for filling, dispensing, and gravity feed operations.



Certifications

- » Title 49 CFR Compliant
- » UN31H2 Labeled
- » IMDG Certified
- » UN/DOT Approved for Non-Hazardous, Hazardous Packing Group II and III Cargo
- » Approved for Transit by Highway, Rail, and Sea Maritime Vessels
- » Rotational Mold Manufactured from FDA Approved High Density Polyethylene
- » 1.9 Specific Gravity for Up To 15.85 lbs./gal
- » 550 Gallon HD, 550 Gallon LX Models
- » Approved to Transport, Store, and Distribute Corrosive Acids, Caustic Bases, Solvents, Oxidizers, Alcohols, Esters, and Amines Compatible with High Density Polyethylene



(855) 445-7665



sales@ibctanks.com

Megatainer HD



Capacity	Weight	Width	Length	Height	Fill Cap
550 Gallons	570 lbs	48"	81"	60"	6.5"
Includes Inserts for Top Lift Package w/ Cross Bars and Lifting Lugs			Top Lift Package Optional		



(855) 445-7665



sales@ibctanks.com

Features

HD

Top Lift Package w/ Cross Bars and Eyelets (Optional)

Full width cross bars and 4 eyelets for even, stable, secure lifting via crane and hoist equipment.

Protected, Recessed IBC Top Fittings

Structural ribs extend above IBC top to protect fittings from damage.

Heavy Duty IBC Tote Engineering Design

Horizontal, cylindrical tank with integral legs, ribs, and base for heavy-duty performance

Cylindrical Shaped, Inner IBC Tank

Cylinder-shaped tank improves structural strength and cleaning capability.

Extended IBC Tank Frame

IBC frame extends beyond the tank to both protect the tank and maintain a cubical shape.

Pressure Tested to 14.7 PSI (1 ATM, 101.3 kPa)

UN/DOT tested and certified to withstand pressure rating and self-regulate.

SDS / Placard Holder and Protector (Optional)

Holder protects important safety documents and keeps them readily accessible.

One 2" NPS Rieke Polyethylene Bung

One top-located bung allows container access for filling and accessories.

Perfect Stack Stacking Alignment Grooves

Stacking alignment grooves molded into the IBC frame ensures perfect, secure stacking.

S.I. 2" NPS Vacuum Relief Vent

Automatic pressure relief vent built into the IBC lid prevents container over-pressurization.

6.5" Threaded, Vented GEM Cap

Easy tighten, secure sealing lid with tether ensures ease of application security and use.

Molded In UN/DOT Certification Label

IBC tote UN/DOT info is clearly listed on the IBC face for fast, easy reference.

Molded In Volume Markers US Gallon / Metric Liter

Volume indicators molded into the tank exterior allow visual monitoring of current liquid levels.

Recess Protected Drain Valve

Drain valve is recessed inside the tank shell to protect against accidental impacts.

Tote Built-in Ball Valve

Banjo 2" bolted glass-filled polypropylene quick connect drain valve with dust cap and lanyard.

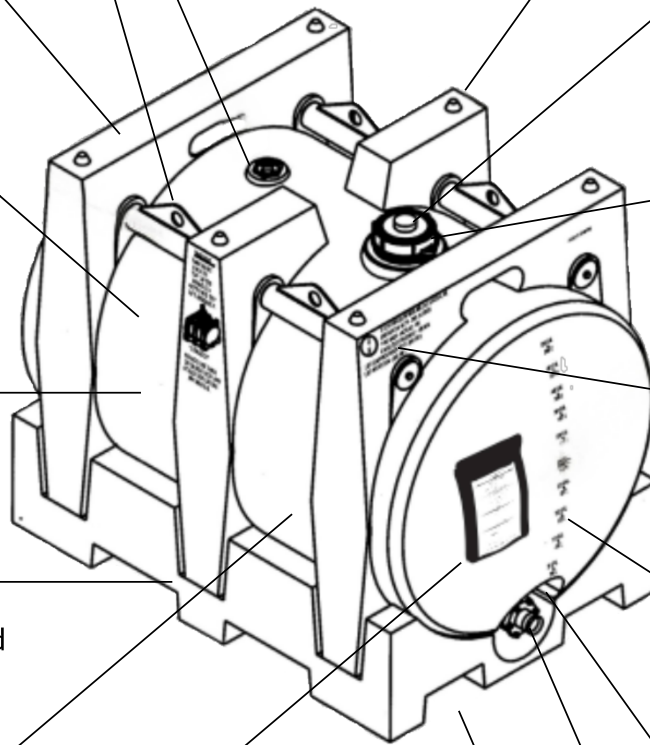

Pallet Style Base Forklift Channels

4-way, cross-directional access for pallet jack and forklift maneuverability.



Dimensions

550 Gallon HD

Side View

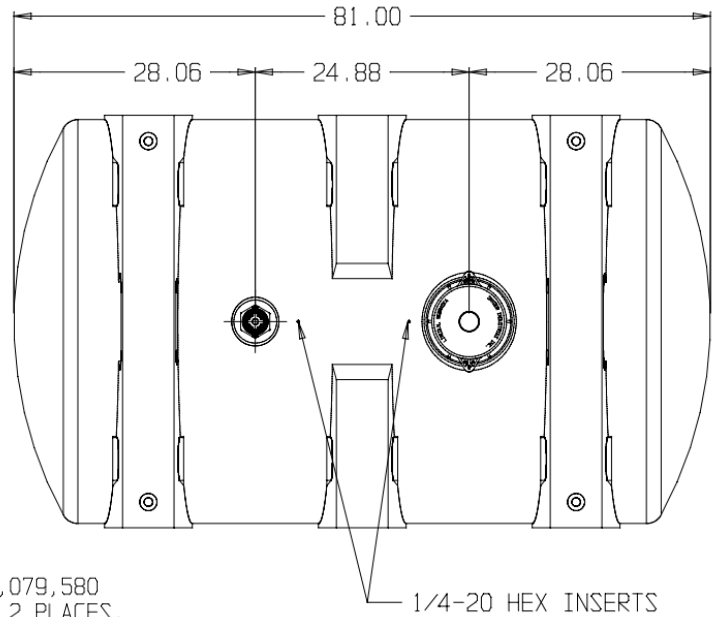
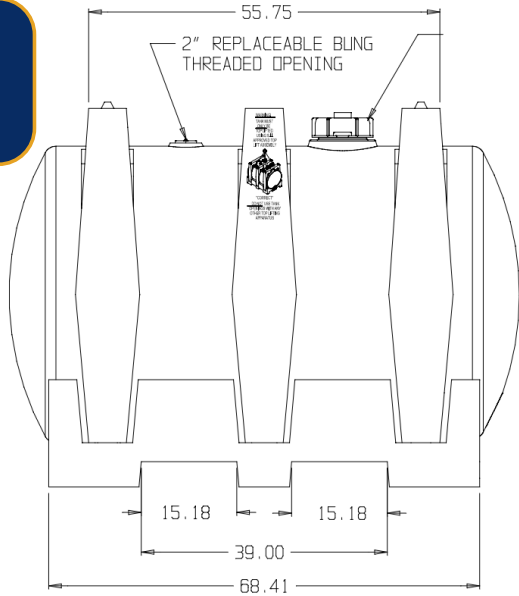

Front View

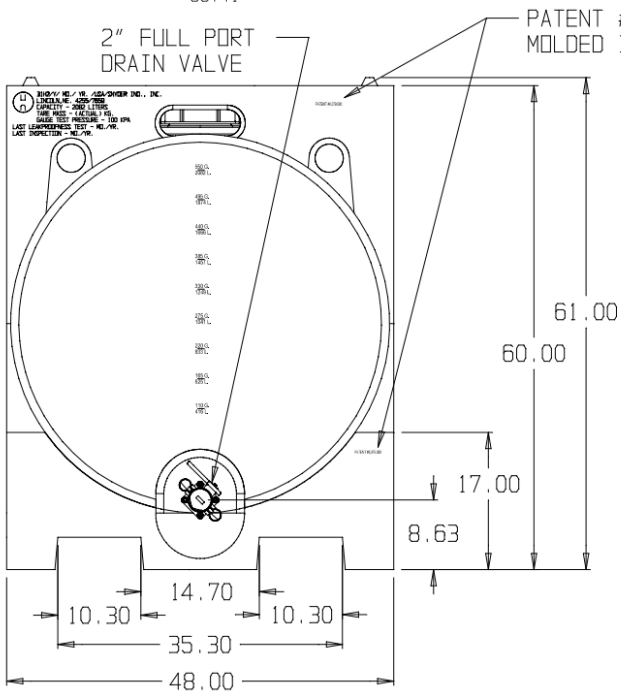

Top View

Parts List

1	TANK - 1 BUNG TANK W/ 6.5" CAP, LANYARD INSERT, BOTTOM DRAIN, HDPE NATURAL
2	BASE - 550 GAL MEGATAINER HDPE RED
3	BUNG - 2" NPS RIEKE PE BUNG PLUG W/ FLAT EPDM GASKET
4	LID - 6.5" GEM CAP W/ NPS CENTER OPENING, EPDM GASKET, EQUIPPED W/ LID TIE
5	VENT - 2" SII NPS VACUUM RELIEF VENT W/ EPDM DISK AND GASKET
6	VALVE - 2" BANJO FULL PORT, GLASS FILLED PP BOTTOM DRAIN VALVE W/ TEFLON SEATS, BALL, AND 18/8 SS BOLTS, DUST CAP AND LANYARD
7	TOP LIFT - MOLDED IN INSERTS FOR OPTIONAL TOP LIFT PACKAGE

U.N. MARKING ON TANK READS:



31H2/Y/ MO./ YR. /USA/SNYDER IND., INC.
LINCOLN, NE. 0 / 4255
CAPACITY - 2082 LITERS
TARE MASS - (ACTUAL) KG.
GAUGE TEST PRESSURE - 100 KPA

LAST LEAKPROOFNESS TEST - MO./YR.
LAST INSPECTION - MO./YR.



(855) 445-7665



sales@ibctanks.com

Megatainer LX



Capacity	Weight	Width	Length	Height	Fill Cap
550 Gallons	542 lbs	48"	81"	60"	6.5"
Does Not Include Inserts for Top Lift Package			No Option for Top Lift Package		



(855) 445-7665



sales@ibctanks.com

Features

LX

No Top Lift Package Option

Main feature difference. Top lift package option is not available for the Megatainer LX.

Protected, Recessed IBC Top Fittings

Structural ribs extend above IBC top to protect fittings from damage.

Heavy Duty IBC Tote Engineering Design

Horizontal, cylindrical tank with integral legs, ribs, and base for heavy-duty performance

Cylindrical Shaped, Inner IBC Tank

Cylinder-shaped tank improves structural strength and cleaning capability.

Extended IBC Tank Frame

IBC frame extends beyond the tank to both protect the tank and maintain a cubical shape.

Pressure Tested to 14.7 PSI (1 ATM, 101.3 kPa)

UN/DOT tested and certified to withstand pressure rating and self-regulate.

One 2" NPS Rieke Polyethylene Bung

One top-located bung allows container access for filling and accessories.

Perfect Stack Stacking Alignment Grooves

Stacking alignment grooves molded into the IBC frame ensures perfect, secure stacking.

S.I. 2" NPS Vacuum Relief Vent

Automatic pressure relief vent built into the IBC lid prevents container over-pressurization.

6.5" Threaded, Vented GEM Cap

Easy tighten, secure sealing lid with tether ensures ease of application security and use.

Molded In UN/DOT Certification Label

IBC tote UN/DOT info is clearly listed on the IBC face for fast, easy reference.

Molded In Volume Markers US Gallon / Metric Liter

Volume indicators molded into the tank exterior allow visual monitoring of current liquid levels.

Recess Protected Drain Valve

Drain valve is recessed inside the tank shell to protect against accidental impacts.

Tote Built-in Ball Valve

Banjo 2" bolted glass-filled polypropylene quick connect drain valve with dust cap and lanyard.

Pallet Style Base Forklift Channels

4-way, cross-directional access for pallet jack and forklift maneuverability.

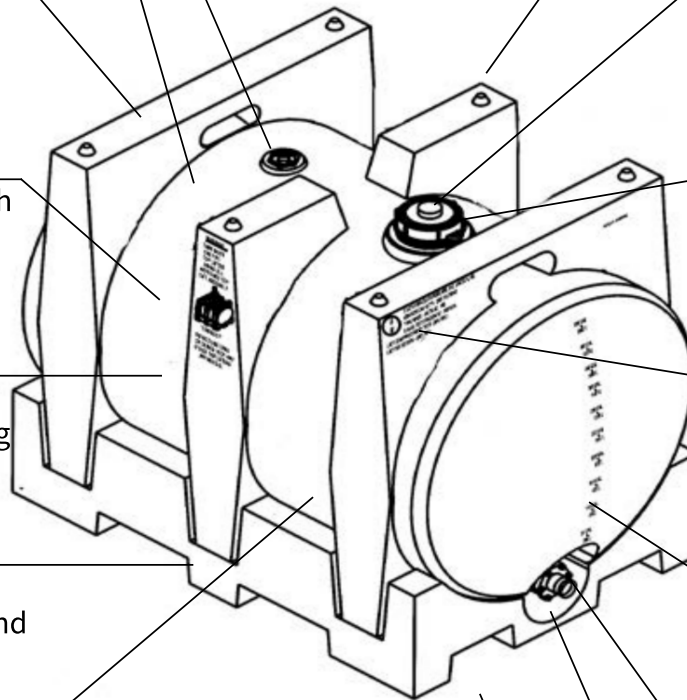

Dimensions

550 Gallon LX

Side View

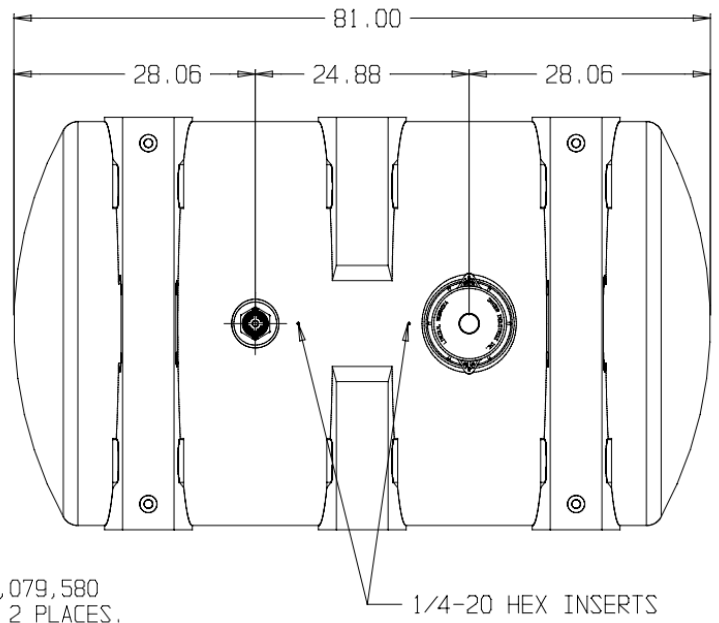
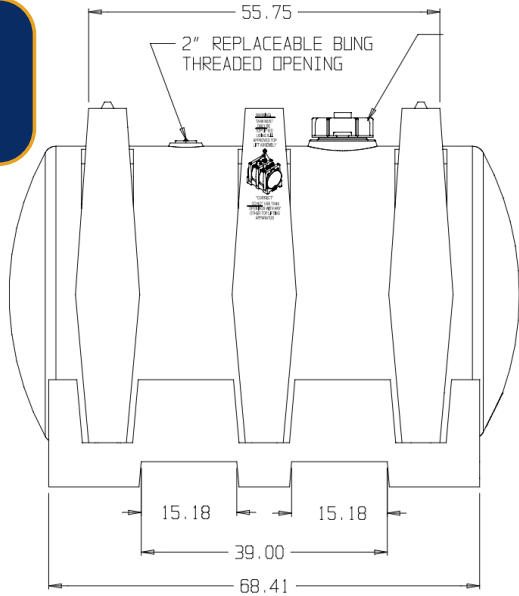

Front View

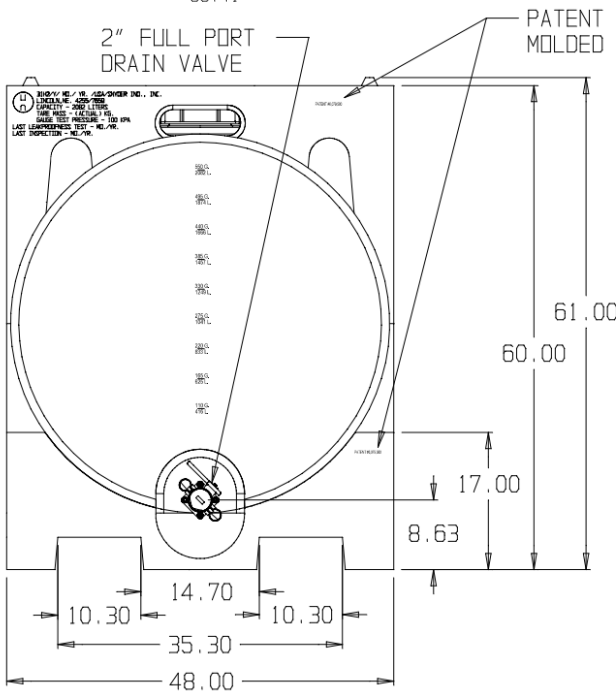

Top View

Parts List

1	TANK - 1 BUNG TANK W/ 6.5" CAP, LANYARD INSERT, BOTTOM DRAIN, HDPE NATURAL
2	BASE - 550 GAL MEGATAINER HDPE RED
3	BUNG - 2" NPS RIEKE PE BUNG PLUG W/ FLAT EPDM GASKET
4	LID - 6.5" GEM CAP W/ NPS CENTER OPENING, EPDM GASKET, EQUIPPED W/ LID TIE
5	VENT - 2" SII NPS VACUUM RELIEF VENT W/ EPDM DISK AND GASKET
6	VALVE - 2" BANJO FULL PORT, GLASS FILLED PP BOTTOM DRAIN VALVE W/ TEFLON SEATS, BALL, AND 18/8 SS BOLTS, DUST CAP AND LANYARD
7	TOP LIFT - SOLID WALL, NO INSERTS FOR OPTIONAL TOP LIFT PACKAGE

U.N. MARKING ON TANK READS:

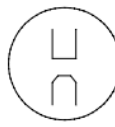
 31H2/Y/ MO./ YR. /USA/SNYDER IND., INC.
 LINCOLN, NE. 0 / 4255
 CAPACITY - 2082 LITERS
 TARE MASS - (ACTUAL) KG.
 GAUGE TEST PRESSURE - 100 KPA
 LAST LEAKPROOFNESS TEST - MO./YR.
 LAST INSPECTION - MO./YR.



(855) 445-7665



sales@ibctanks.com

IBC TANKS

THE IBC TOTES AUTHORITY



(855) 445-7665



sales@ibctanks.com

CORROSIVE
LIQUID, N.O.S.

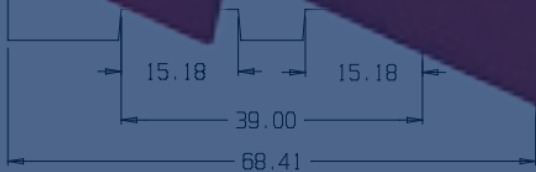

TANK MARKING:

